

Application Bulletin AB-9

Suppressing MOSFET Gate Ringing in Converters: Selection of a Gate Resistor

Summary

To prevent gate ringing, while not harming efficiency, Fairchild recommends careful board layout, and use of a 4.7Ω gate resistor for every power MOSFET used in a switching converter; in particular, use a separate 4.7Ω gate resistor for each paralleled MOSFET.

Description of MOSFET Gate Ringing

Not infrequently, the power MOSFETs used in a switching converter may be observed to have a high-frequency oscillation or ringing on their gate-to-source voltage. Sometimes this ringing will be harmless; for example, it may occur after the gate voltage has reached its steady-state voltage for the period, and then it has little impact on performance. On the other hand, it may be a very significant source of dissipation in the MOSFET, to the point where the MOSFET might fail because of it: if the ringing occurs after the MOSFET is turned off, and the ringing amplitude is large enough to periodically turn on the MOSFET during this off-state.

It sometimes happens that the gate ringing is present, and the engineer is unaware of it. The oscillations can easily be 100MHz or higher (into the FM radio band!), and so a digital sampling oscilloscope may alias away the oscillation signal. To be sure that ringing doesn't exist, it is necessary to use either a high-end analog oscilloscope, or else a very-fast digital oscilloscope with adequate memory.

The Cause of Gate Ringing: Single MOSFET

Consider first a single power MOSFET being driven by a low impedance driver, such as any of the Fairchild RC5000 series ICs. A model of the MOSFET that includes its parasitics at once makes evident the source of the gate oscillations:

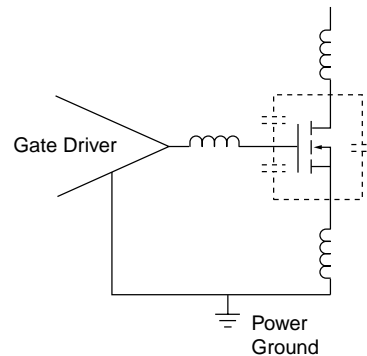

Figure 1. Model of a Power MOSFET Including Parasitics

The MOSFET has both parasitic capacitances and parasitic inductances, and these form a resonant tank that can be excited into oscillation. Although the MOSFET has parasitic inductance, it should also be realized that in many cases the dominant inductance is caused by long traces. The parasitic inductance and trace inductance are in series, and both contribute to the tank.

The Cause of Gate Ringing: Parallel MOSFETs

Consideration of the MOSFET model shown in Figure 1 also reveals what can happen if multiple MOSFETs are paralleled. Each MOSFET individually forms a resonant tank, and in addition, there are other resonant tanks formed by the parallel and series combinations of the inductances and capacitances. The result is that two or more MOSFETs in parallel may well oscillate even when a single one doesn't; in addition, the system of multiple MOSFETs is capable of oscillation at a number of different frequencies, corresponding to the various tanks' natural frequencies.

The Cure for Gate Ringing

The most important means of avoiding ringing is minimizing the inductance, which means having as short a trace length as possible between the gate driver and the gate. Fairchild's Application Note 50 discusses layout in detail.

The model of the MOSFET's parasitics also makes it evident what one possible solution would be to suppressing this ringing if layout is less than optimal: addition of a damping resistor to decrease the Q of the tank. In particular, adding a resistor in series with the gate will suppress oscillations. **The resistor should be as close as physically possible to the gate of the MOSFET.**

In the case of multiple paralleled MOSFETs, since there are multiple resonant tanks, having a single gate resistor is not enough: the only way to ensure that there will not be ringing is for each individual MOSFET to have its own gate resistor.

What Value of Gate Resistor?

Unfortunately, it is not possible to just put an arbitrarily large resistor in the gate of the power MOSFET. Resistance causes the gate voltage to rise slowly (because it is an R-C filter), which in turn causes the MOSFET to switch slowly, decreasing the efficiency of the converter. As an example, the efficiency of Fairchild's VRM RCB005 was measured with various values of gate resistance, including zero:

Gate Resistance (Ω)	Change in Efficiency
0	0 (nominal)
3.3	-0.4%
4.7	-0.8%
10	-2.9%
20	-5.6%

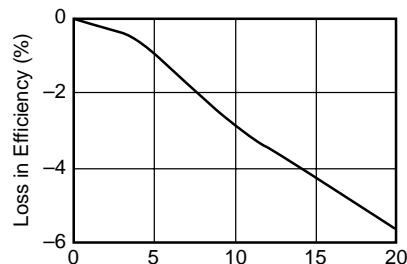

As can be seen, efficiency decreases as gate resistance increases. To ensure oscillation suppression while avoiding degradation of converter efficiency, Fairchild recommends:

Use a 4.7 Ω gate resistor for every power MOSFET used in a switching converter; in particular, use a separate 4.7 Ω gate resistor for each paralleled MOSFET.

Revised RC5051 Schematic

Reflecting this recommendation, a revised RC5051 schematic (adapted from the RC5051 datasheet Figure 1) is shown here:

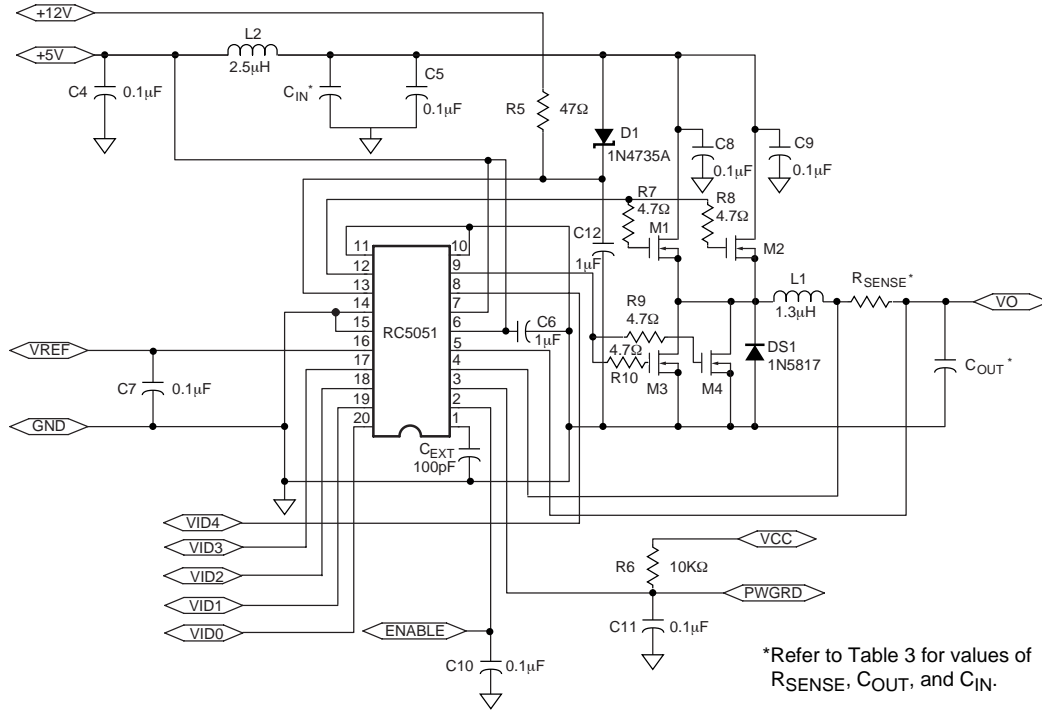

AB9-02

Figure 2. 13A Application Circuit for 2.0V Pentium II Processor, Showing Gate Resistors

LIFE SUPPORT POLICY

FAIRCHILD'S PRODUCTS ARE NOT AUTHORIZED FOR USE AS CRITICAL COMPONENTS IN LIFE SUPPORT DEVICES OR SYSTEMS WITHOUT THE EXPRESS WRITTEN APPROVAL OF THE PRESIDENT OF FAIRCHILD SEMICONDUCTOR CORPORATION. As used herein:

1. Life support devices or systems are devices or systems which, (a) are intended for surgical implant into the body, or (b) support or sustain life, and (c) whose failure to perform when properly used in accordance with instructions for use provided in the labeling, can be reasonably expected to result in a significant injury of the user.
2. A critical component in any component of a life support device or system whose failure to perform can be reasonably expected to cause the failure of the life support device or system, or to affect its safety or effectiveness.